

Art. - Nr.: 6023



1

8 - 99

15 min. - ∞

Cheer Puzzle



Autor: Ronald Kint-Bruynseels

Dieses Puzzle besteht aus 3 Teilen, die in Form eines Knotens zusammengesteckt sind. Ziel des Spiels ist es, den Knoten zu zerlegen und die ähnlich aussehenden Teile in der richtigen Reihenfolge wieder zum Knoten zusammenzufügen.

Cheer Puzzle



Author: Ronald Kint-Bruynseels

This puzzle of skill consists of 3 pieces which have to be put together to resemble a knot. The aim is to take it apart and to put it back together again in the right order. The difficulty is that all parts look very similar

Cheer Puzzle



Auteur : Ronald Kint-Bruynseels

Ce jeu d'adresse se compose de 3 pièces de bois de formes différentes qui sont assemblées de manière à former un noeud. Le but du ce jeu est tout d'abord de défaire le noeud et ensuite de le reconstituer.

Cheer Puzzle



Autor: Ronald Kint-Bruynseels

Este puzzle consta de 3 piezas, que se ensamblan en la forma de un nudo. El objetivo del juego es desmontar el nudo y las piezas de aspecto similar juntos en el orden correcto para el nudo.

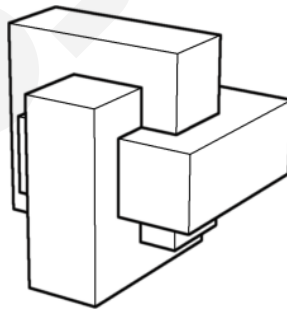

Teile / Pieces / Pièces / Piezas

a

b

c

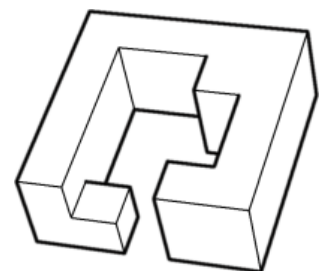
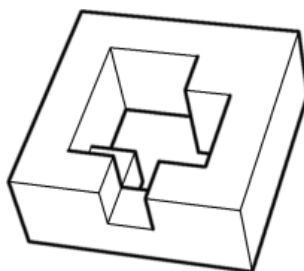
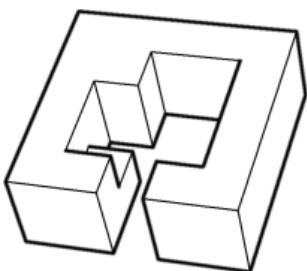

Philos GmbH & Co. KG
Friedrich-List-Str. 65
33100 Paderborn
www.philosspiele.de

Lösung / Solution / Solution / Solución

1 b:

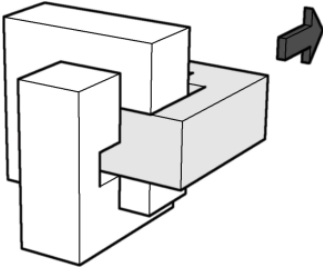

2 a:

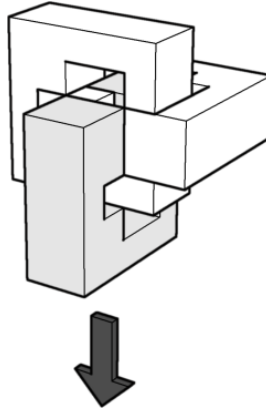

3 a:

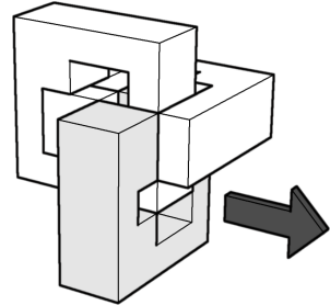

4 c:

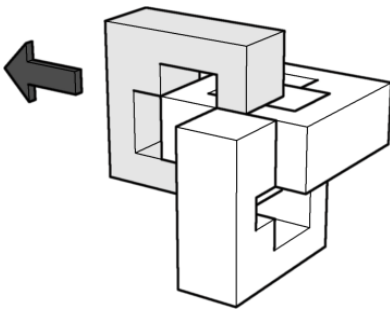

5 b:

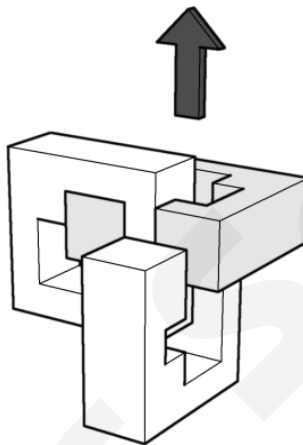

6 c:

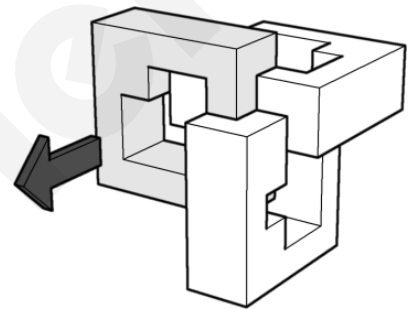

7 a:

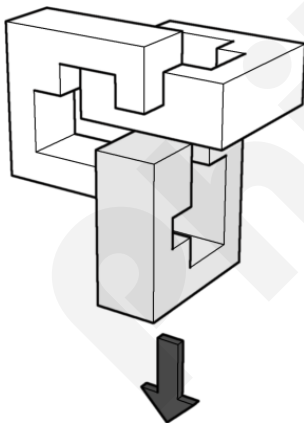

8 a:

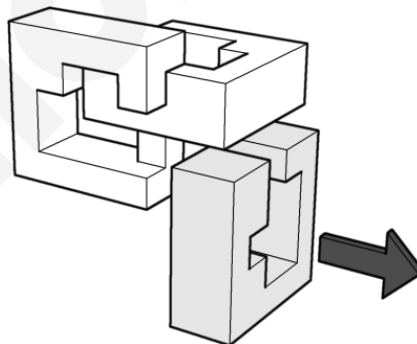

9 c:

